

**THREE-90 MODE SWITCH WIRING
SALECOM T80T845-ZBQE-H**

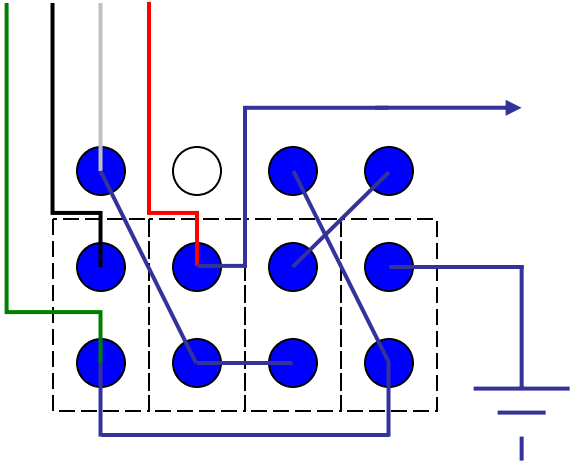

CLEAN: 3+2 PARALLEL
 WHITE – RED (PARA HOT)
 BLACK – GREEN (PARA GND)

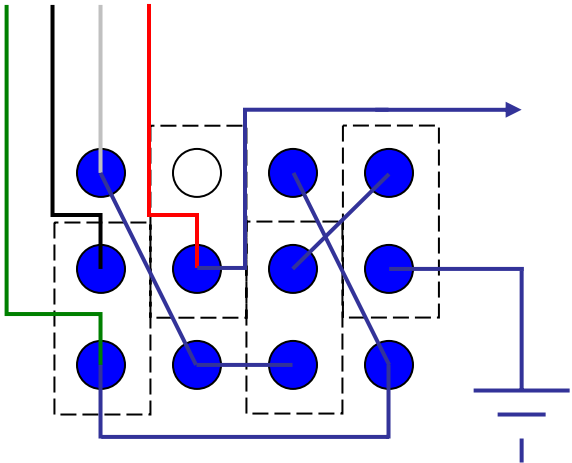

CRUNCH: 3+1 SERIES
 BLACK – GREEN (SERIES JUNCTION)
 WHITE TO GROUND

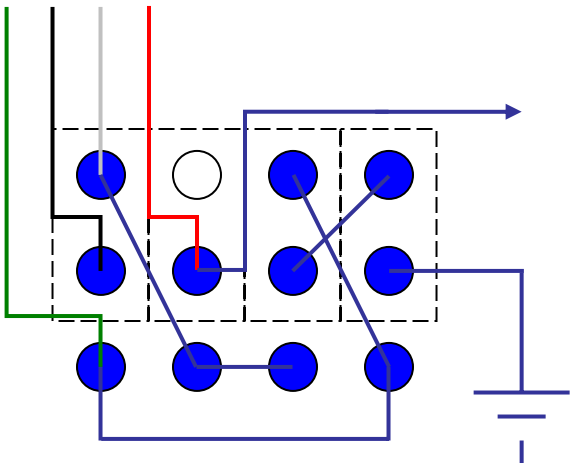

LEAD: 3+2 SERIES
 WHITE – BLACK (SERIES JUNCTION)
 GREEN TO GROUND

- SWITCH MOUNTED WITH KEY SLOT DOWN
- PICKUP SHIELD CONNECTS TO SWITCH GROUND
- ALL JUMPERS INSULATED

**COAXE MODE SWITCH WIRING
SALECOM T80T845-ZBQE-H**

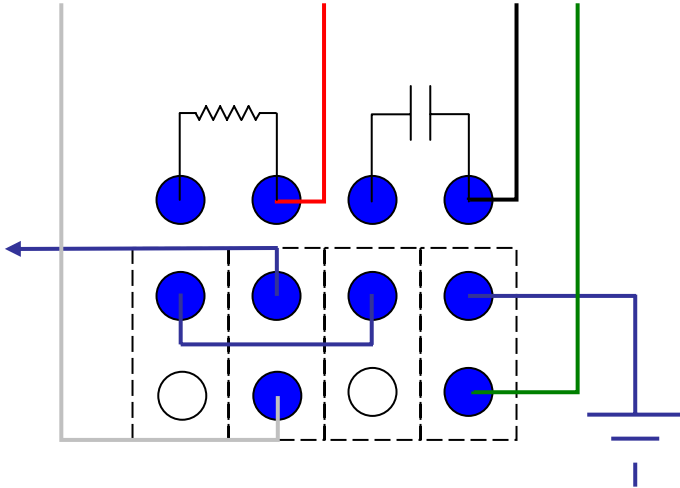

CLEAN: BOTH COILS TAPPED
WHITE – OUTPUT
GREEN – GROUND

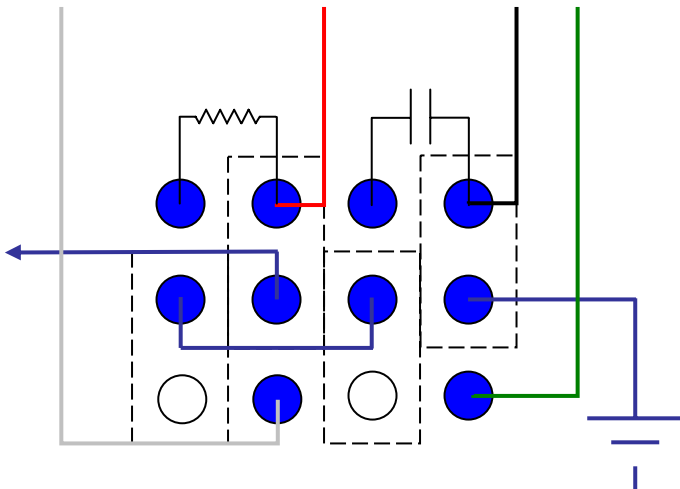

CRUNCH: BOTH COILS FULL
RED – OUTPUT
BLACK – GROUND

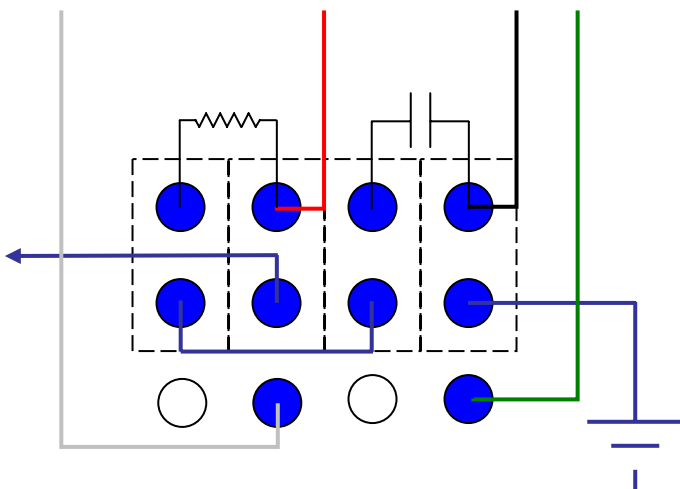

LEAD: BOTH COILS FULL + RC
RED – OUTPUT
BLACK – GROUND

- SWITCH MOUNTED WITH KEY SLOT DOWN
- PICKUP SHIELD CONNECTS TO SWITCH GROUND
- ALL JUMPERS INSULATED

**THREE-90 MODE SWITCH WIRING
OTAX F4TPA11**

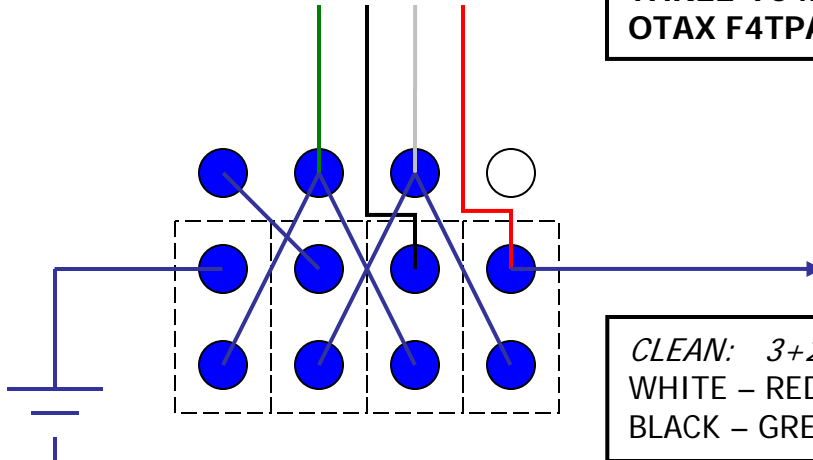

CLEAN: 3+2 PARALLEL
WHITE – RED (PARA HOT)
BLACK – GREEN (PARA GND)

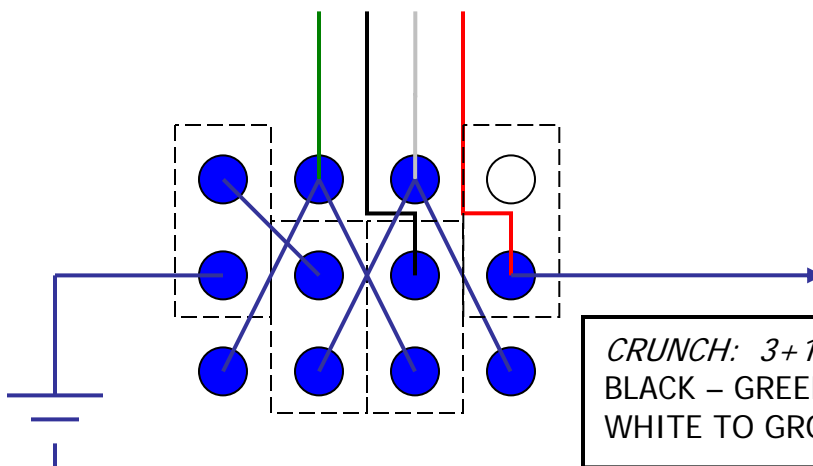

CRUNCH: 3+1 SERIES
BLACK – GREEN (SERIES JUNCTION)
WHITE TO GROUND

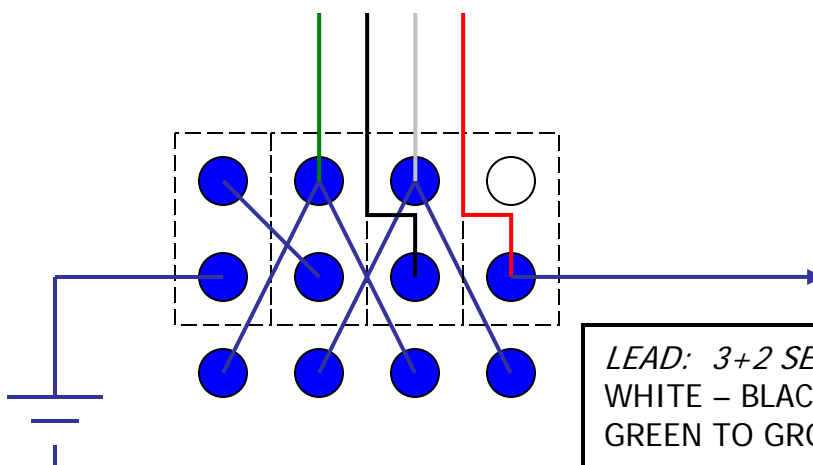

LEAD: 3+2 SERIES
WHITE – BLACK (SERIES JUNCTION)
GREEN TO GROUND

- SWITCH MOUNTED WITH KEY SLOT DOWN
- PICKUP SHIELD CONNECTS TO SWITCH GROUND
- ALL JUMPERS INSULATED

**COAXE MODE SWITCH WIRING
OTAX F4TPA11**

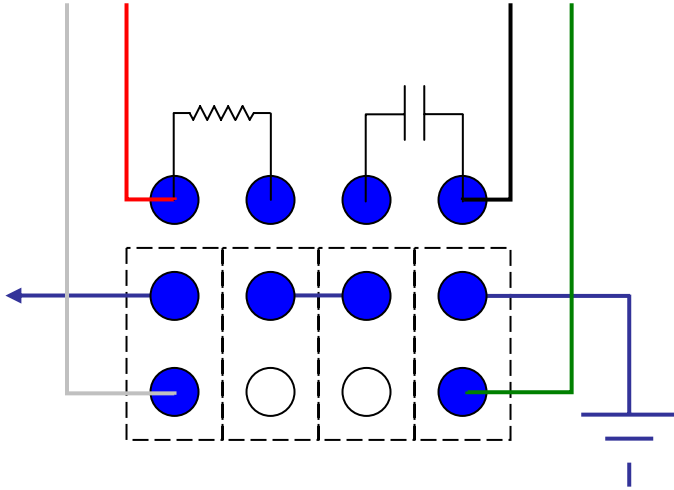

CLEAN: BOTH COILS TAPPED
WHITE – OUTPUT
GREEN – GROUND

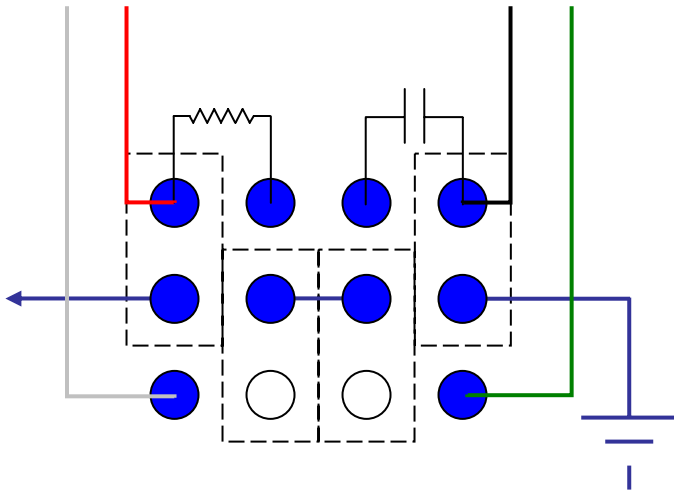

CRUNCH: BOTH COILS FULL
RED – OUTPUT
BLACK – GROUND

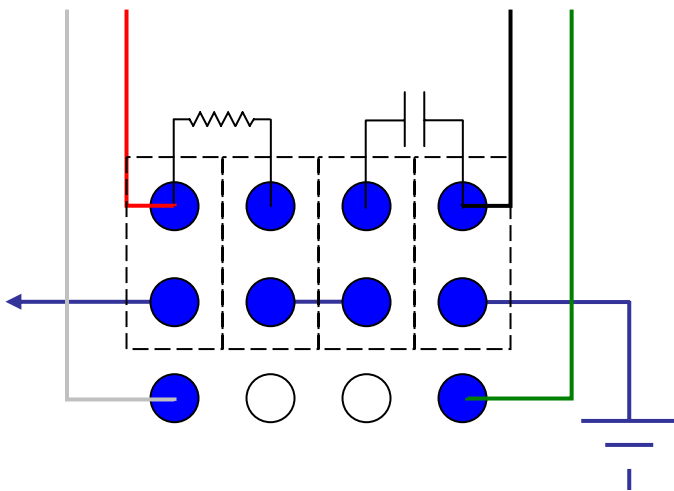

LEAD: BOTH COILS FULL + RC
RED – OUTPUT
BLACK – GROUND

- SWITCH MOUNTED WITH KEY SLOT DOWN
- PICKUP SHIELD CONNECTS TO SWITCH GROUND
- ALL JUMPERS INSULATED